



12AYM-WGT

L-rating 1340kW (1822mhp)



Dimensions Unit:mm



Engine only / Front view

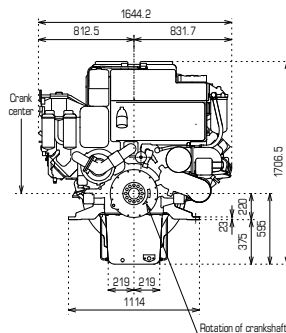

Engine only / Right side view

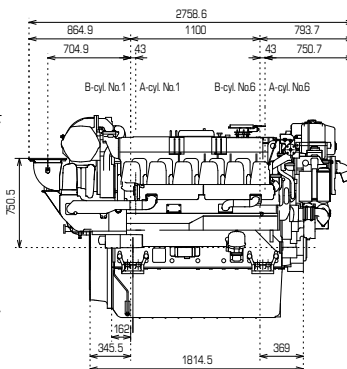

- V-type, 12-cylinder, direct injection, heat exchanger cooling.
- Turbocharger + intercooler.
- 4-valves per cylinder for higher combustion efficiency.
- Conform to IMO Tier II emissions regulations.

Specifications

Model	12AYM-WGT L-rating	
Number of cylinders	12 V-type	
Bore × stroke	mm	155 × 180
Displacement	lit.	40.76
Rated output	kWhp/rpm	L : 1340(1822)/1940
Combustion system	Direct injection	
Aspiration	Turbocharger + intercooler	
Starting system	Electric starting motor (24V-8.0kW)×2 or air motor×2	
Cooling system	Constant high temperature cooling system	
Size of flywheel housing and flywheel	SAE #00 and 21 in.	
Dry mass	kg	4950 (without marine gear)
Dimensions (L×W×H)	mm	2759×1644×1707

Performance curves

