



6LY Series - 400 / 440

Configuration	In-line, 4-stroke, vertical, water-cooled diesel engine	
Max. output at crankshaft*	294 kW@3300 rpm	[400 mhp@3300 rpm]
	324 kW@3300 rpm	[440 mhp@3300 rpm]
No. of cylinders	6 cylinder	
Displacement	5.813 L	[354 cu in]
Bore x stroke	106 mm x 110 mm	[4.17 in x 4.33 in]
Aspiration	Turbocharged & intercooled	
Combustion system	Direct injection, Denso common rail system	
Starting system	Electric starting 12V - 2.5 kW	
Engine management	Electronic	
Cooling system	Fresh water cooling by centrifugal fresh water pump	
	Seawater cooling by rubber impeller seawater pump	
Alternator	12V - 125A	
Lubrication system	Enclosed, forced lubricating system	
Engine lube oil specifications	API class: CD or higher, SAE grade: 10W-30 or 15W-40	
Direction of rotation at crankshaft	Counterclockwise (CCW) viewed from stern	
Dry weight without gear	585 kg	[1290 lbs]
Engine dimensions† L x W x H	1440 x 748.5 x 773.8 mm	
Emission compliance	EU: RCD 2, EMC, IMO/GL	US: EPA Tier 3, EPA-C
Flywheel housing size	SAE #3	
Controls	Electronic	

NOTE: Fuel condition: Density at 15°C = 0.84 g/cm³; 1 kW = 1.3596 mhp = 1.3410 HP

Technical data is according to (ISO 8665) / (ISO 3046)

* Fuel temperature 40°C at the inlet of the fuel injection pump (ISO 8665: 2006)

†Length measured with with KMH61A-2 gearbox & high-riser elbow (Dimensions may vary with other gears/elbow)

DIMENSIONS

Rear view

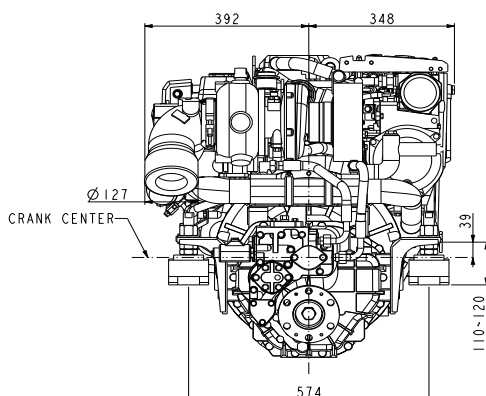

6LY440 with KMH61A2 marine gear
(Not to be used for engine installation)

Right side view

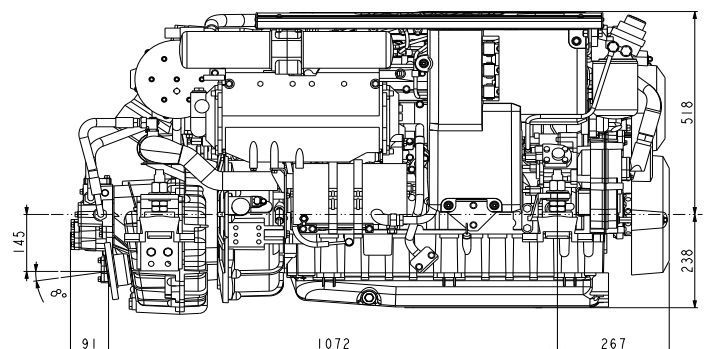



PERFORMANCE CURVES

6LY400 Torque curve

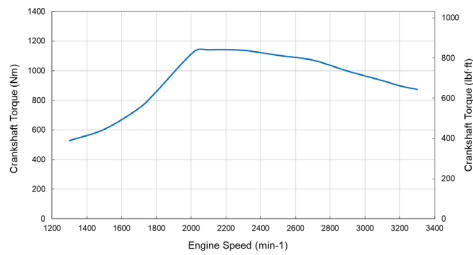

6LY400 Output Power curve

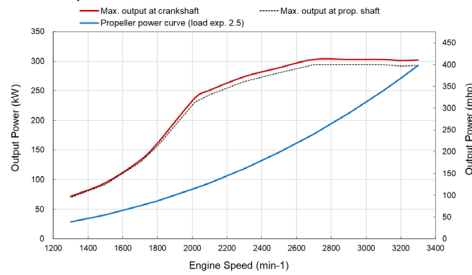

6LY400 Fuel consumption (load exp. 2.5)

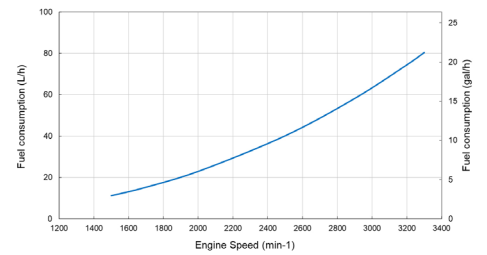

6LY440 Torque curve

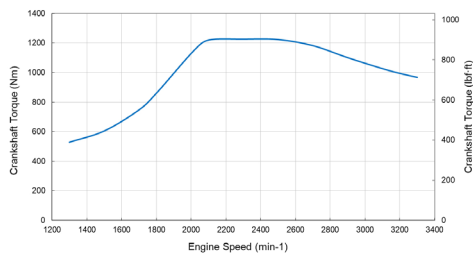

6LY440 Output Power curve

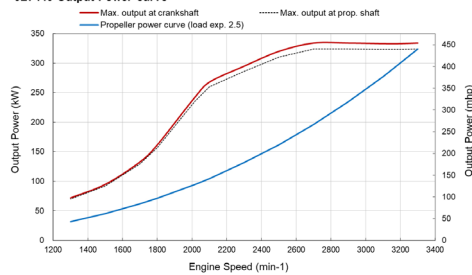

6LY440 Fuel consumption (load exp. 2.5)

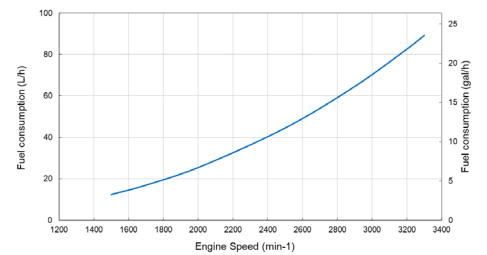

MARINE GEAR*

Model	KMH61A2 [down angle: 8°]			KMH61V2 [V-drive]			ZF280-1A [parallel]	ZF280-1A [down angle 7°]
Clutch type	Hydraulic multi-disc			Hydraulic multi-disc			Hydraulic multi-disc	
Dry weight	76 kg [168 lbs]			108 kg [238 lbs]			86 [190 lb]	
Reduction ratio [fwd/asn]	1.55/1.55	2.04/2.04	2.43/2.43	1.12/1.12	1.26/1.26	2.04/2.04	Gear ratio's as available from ZF	
Direction of rotation [viewed from stern]	Clockwise & counterclockwise			Clockwise & counterclockwise			Clockwise & counterclockwise	
Lubrication system	Forced lubrication			Forced lubrication			Forced lubrication	
Lube oil specifications	API class: CF or higher, SAE grade: #30			API class: CF or higher, SAE grade: #30			API class: CF or higher, SAE grade: #30	
Max. lube oil capacity	2.8 L			8 L			3.3 L	
Dry weight - engine & gear	661 kg [1457 lbs]			693 kg [1527 lbs]			671 kg [1479 lbs]	

* Other marine gearboxes and configurations available upon request. Contact your local supplier for more information.

ACCESSORIES

Standard engine package

- Exhaust mixing elbow [L-type]
- Alternator 12V - 120A
- VC20 Vessel Control System
- Fresh water expansion tank

Optional accessories

- High-riser mixing elbow [instead of L-elbow]
- Flexible mounts Barry
- Flexible mounts Bridgestone
- Secondary alternator 12V - 120A or 24V - 45A
- Secondary alternator 12V - 130A or 24V - 110A including smart regulator
- Extension harness [3m, 5m, 10m]

• Second station

- JC20 Inboard Joystick
- NMEA2000 Engine monitoring system
- SOLAS including Certificate [factory fit only]
- Hot water kit
- Water separator
- Lu oil drain pump
- Bilge pump [12V]

NOTE: All data subject to change without notice. Text and illustrations are not binding.